



USN

--	--	--	--	--	--	--	--	--	--

15ME82

Eighth Semester B.E. Degree Examination, July/August 2021 Additive Manufacturing

Time: 3 hrs.

Max. Marks: 80

Note: Answer any FIVE full questions.

- 1 a. Explain the need for Additive Manufacturing. (06 Marks)
 b. Explain with a neat sketch, the working principle, merits and demerits and applications of Discrete Particle Additive Manufacturing System. (10 Marks)

- 2 a. Distinguish between Additive Manufacturing and CNC Machining. (06 Marks)
 b. Explain with a neat sketch, the working principle, advantages, disadvantages and applications of Solid Sheet additive manufacturing system. (10 Marks)

- 3 a. Explain with neat sketches, the salient features of DC motors with field coil. (10 Marks)
 b. Explain with neat diagrams, the salient features and characteristics of Thyristor and Triac. (06 Marks)

- 4 a. Explain with neat sketches, the working principle of following hydraulic motors :
 i) Vane motor ii) Gear motor. (08 Marks)
 b. Write a note on the following :
 i) Shape memory alloys ii) Piezo electric actuators. (08 Marks)

- 5 a. Explain the main steps in powder metallurgy. (08 Marks)
 b. Explain with neat sketches the following :
 i) Tape casting ii) Slip casting. (08 Marks)

- 6 a. Explain with a neat sketch, the working principle of polymer processing by wet spinning. What are its advantages and disadvantages? (08 Marks)
 b. Explain in detail Liquid Phase Sintering. (08 Marks)

- 7 a. Explain with neat sketches, Top-down and Bottom-up approaches pertaining to Nanotechnology. (06 Marks)
 b. Explain with a neat sketch, the working principle, uses and applications of Scanning Electron Microscopy (SEM). (10 Marks)

- 8 a. Explain with a neat sketch, production of Ultrafine powders by Mechanical grinding. (06 Marks)
 b. Explain with a neat sketch, the working principle, merits, demerits and application of Atomic Force Microscopy (AFM). (10 Marks)

- 9 a. Explain the various Automation principles and Strategies. (10 Marks)
 b. Distinguish between NC, CNC and DNC systems, with neat block diagrams. (06 Marks)

Important Note : 1. On completing your answers, compulsorily draw diagonal cross lines on the remaining blank pages.
 2. Any revealing of identification, appeal to evaluator and /or equations written eg. 42+8 = 50, will be treated as malpractice.

- 10 a. Explain with a block diagram the various levels of Automation. (08 Marks)
- b. Write an NC part program for the part shown in Fig. Q10(b) depicting drilling operation. (08 Marks)
- Use the following data :
- Spindle speed = 1000 rpm.
 - Feed = 0.05mm/rev.
 - Starting point of tool is at $X = 0$, $Y = -50\text{mm}$, $Z = 10\text{mm}$.
 - Diameter of drill = 7mm.
 - Consider absolute positioning system.

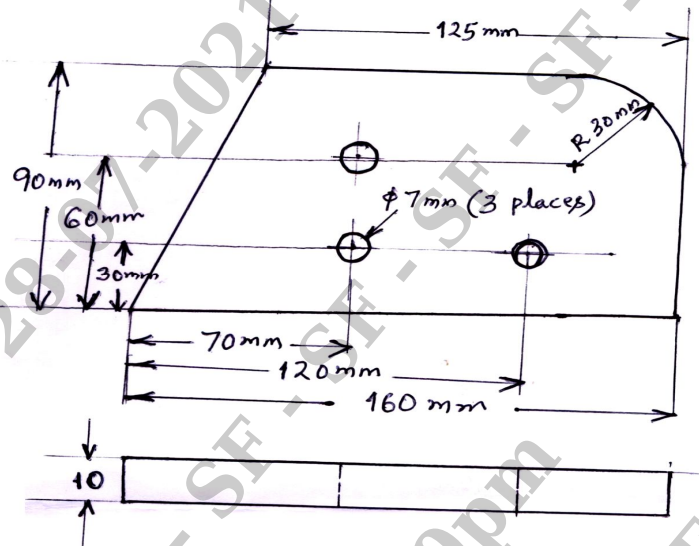

Fig. Q10(b) : A simple part depicting drilling operation
